

S2

P2 Single screen

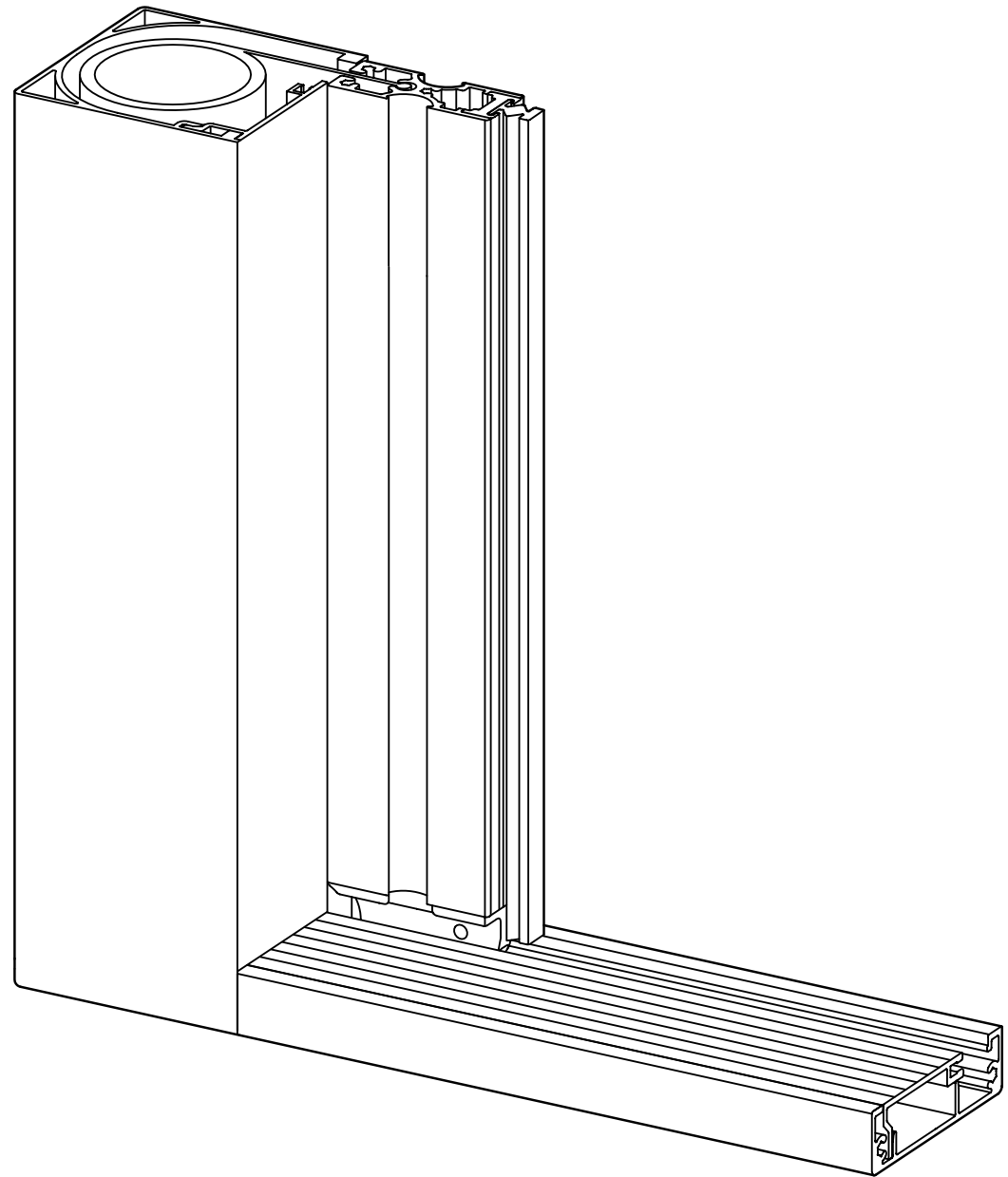

Installation instructions

centor®

Tools required

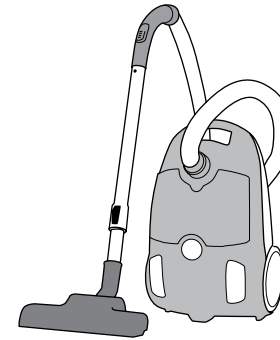
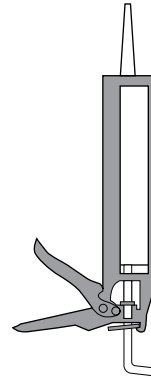
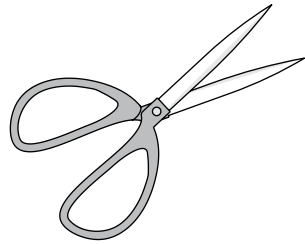

Torx T20

Installer pack – supplied

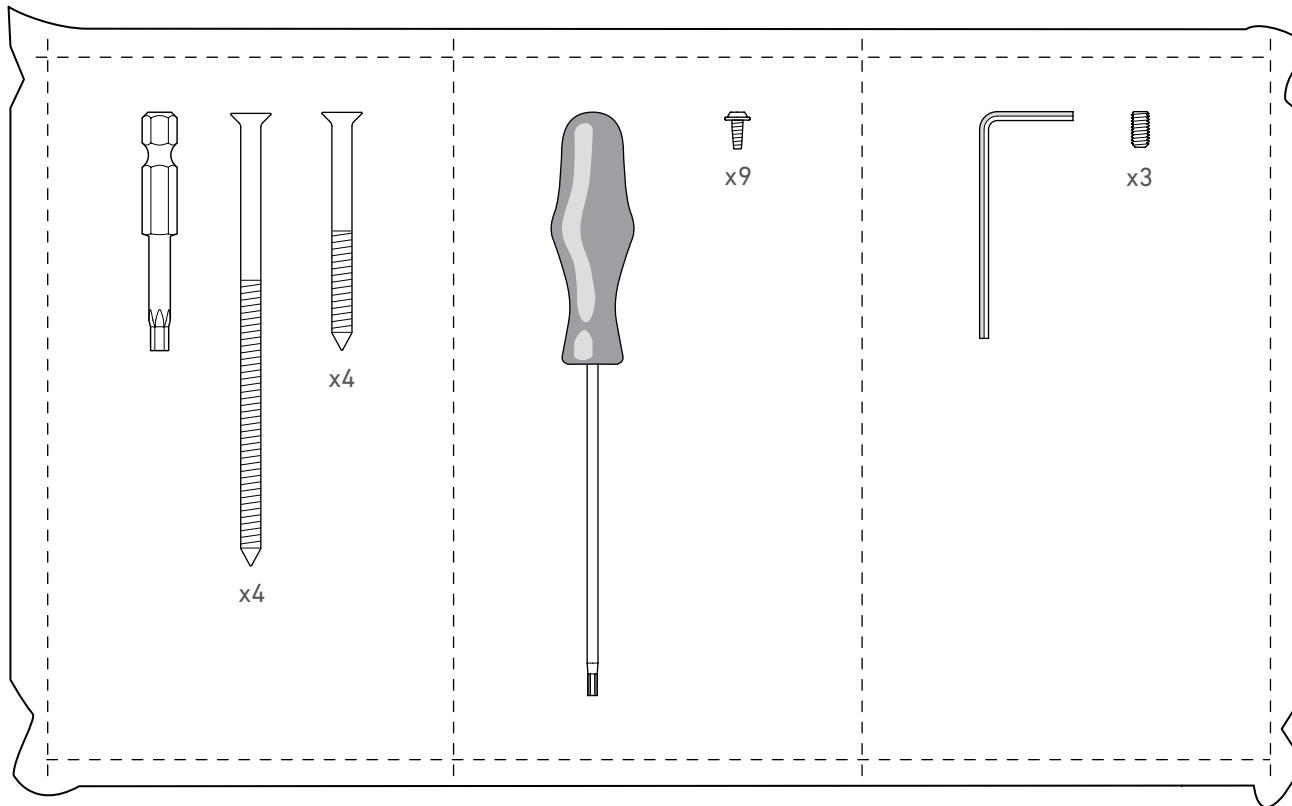

1.0 Check delivery

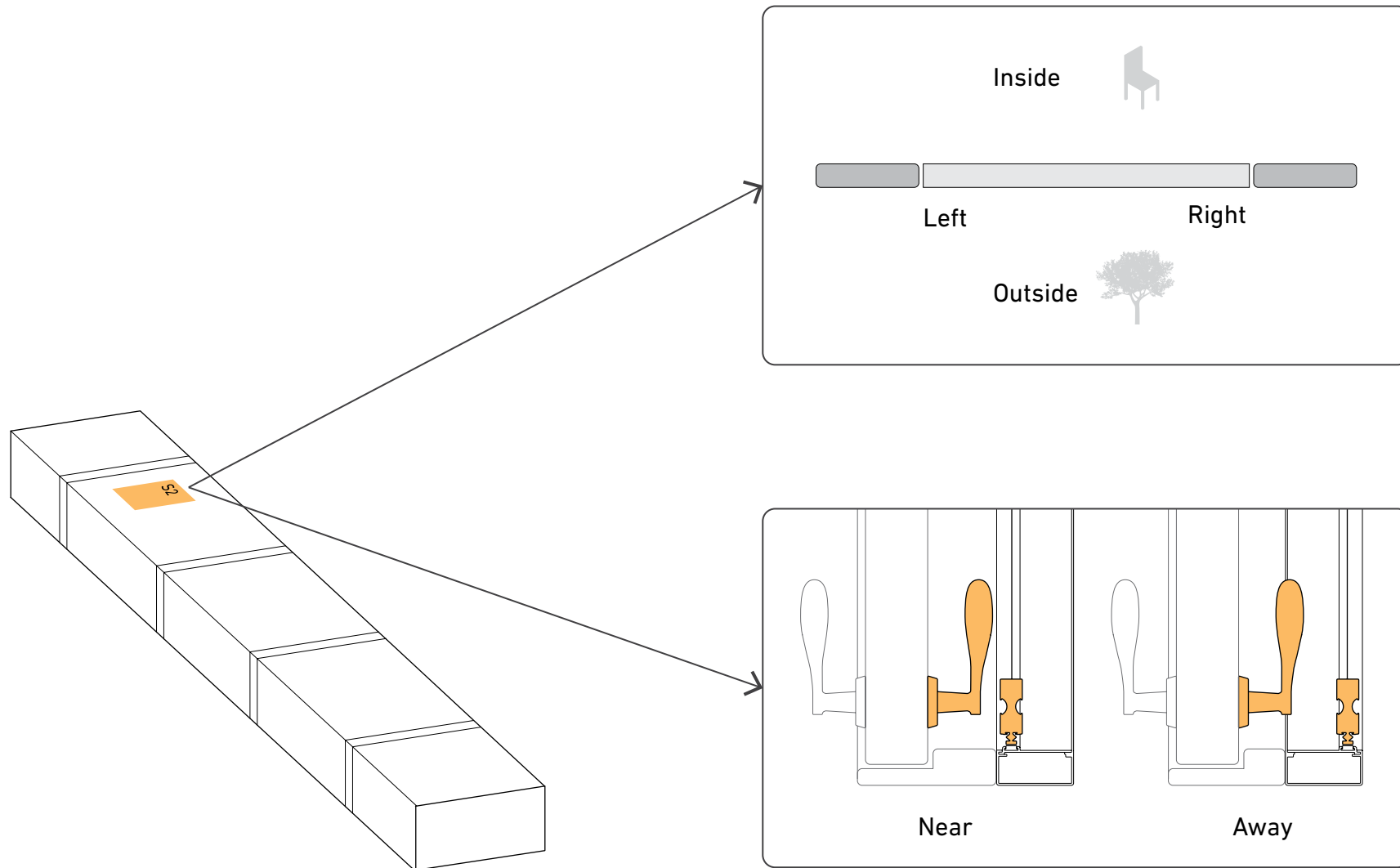

2.0 Assemble frame

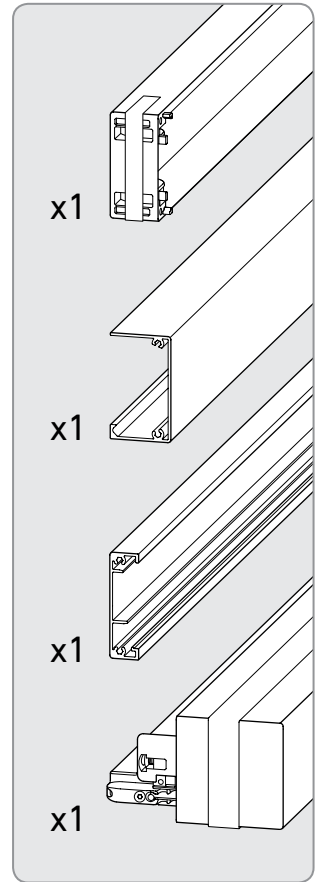
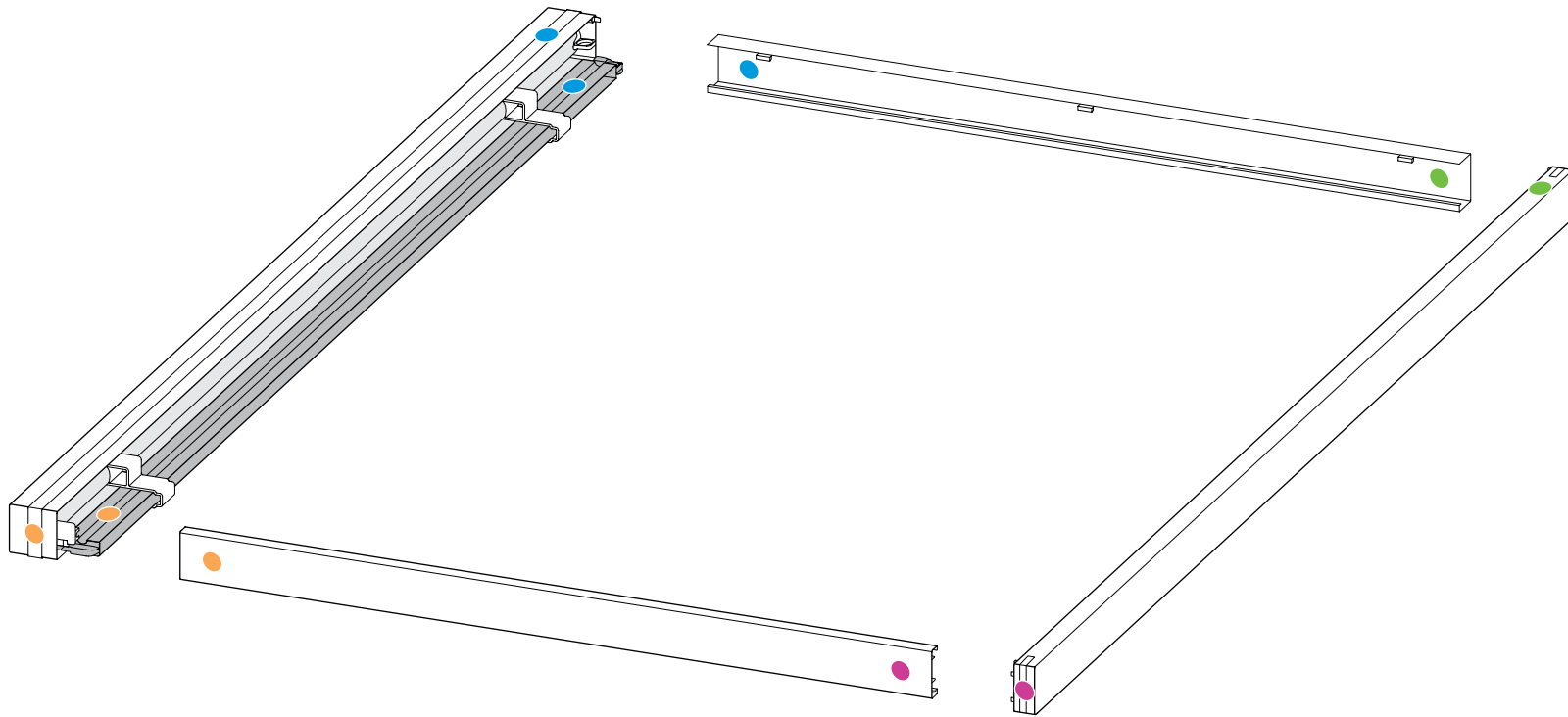

+

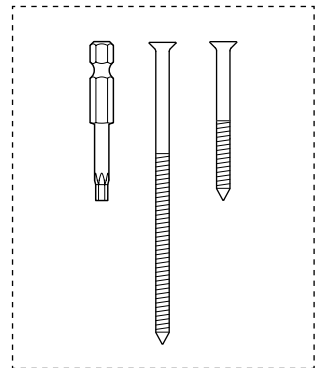

2.1

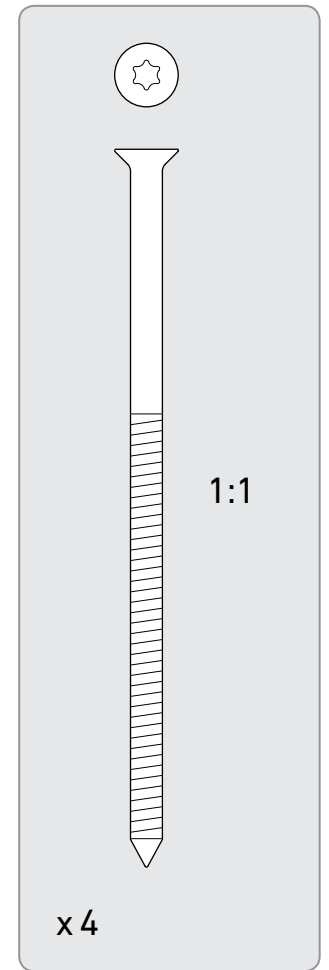
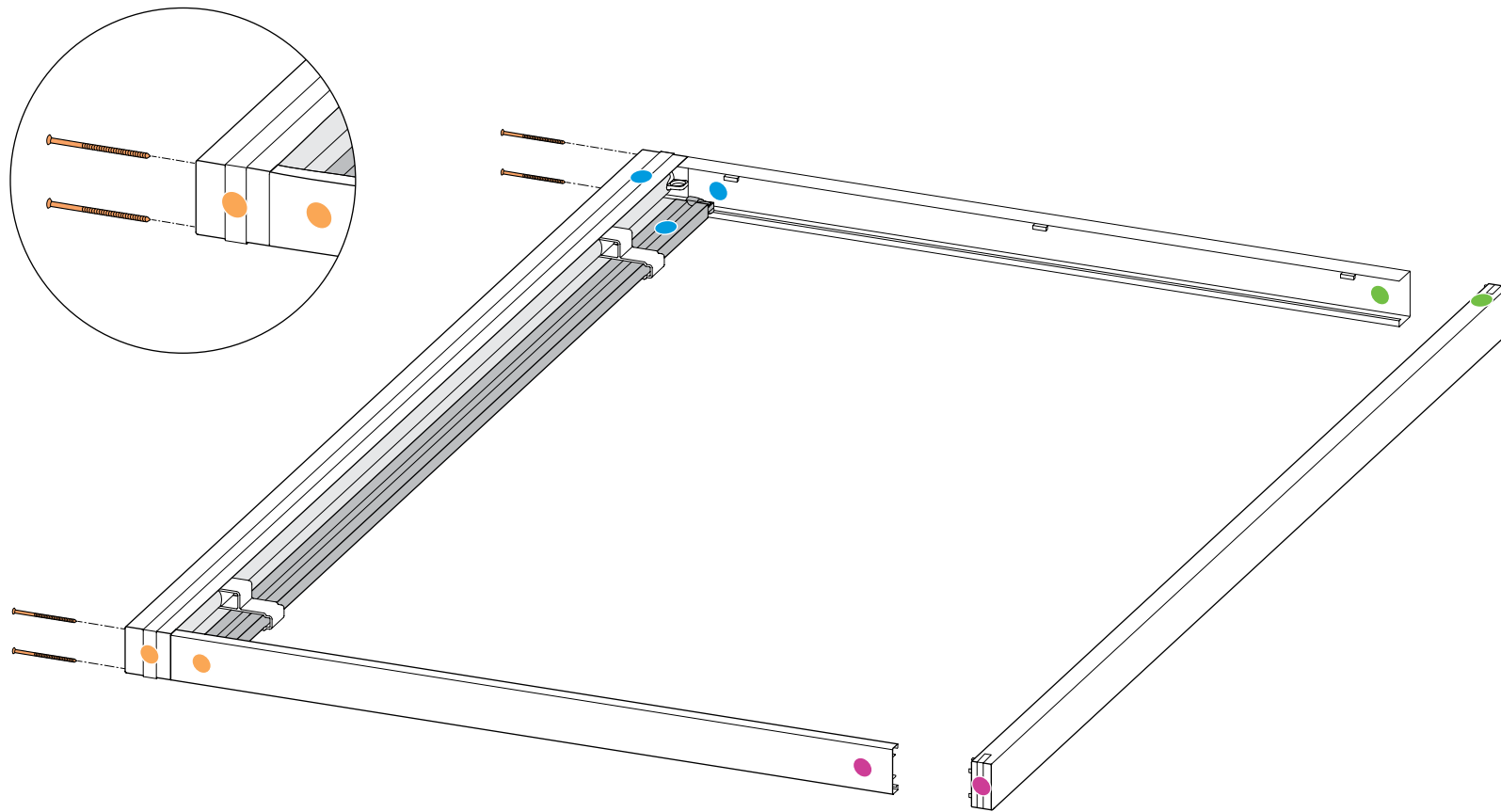

2.2

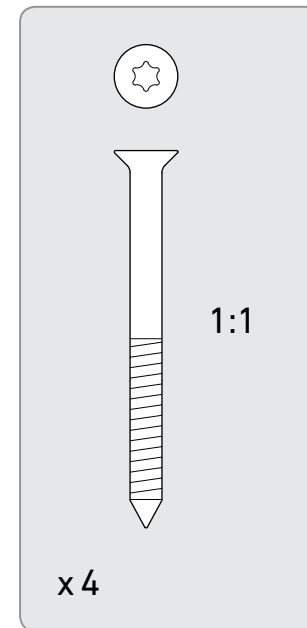
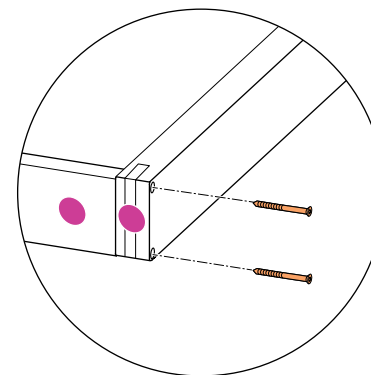
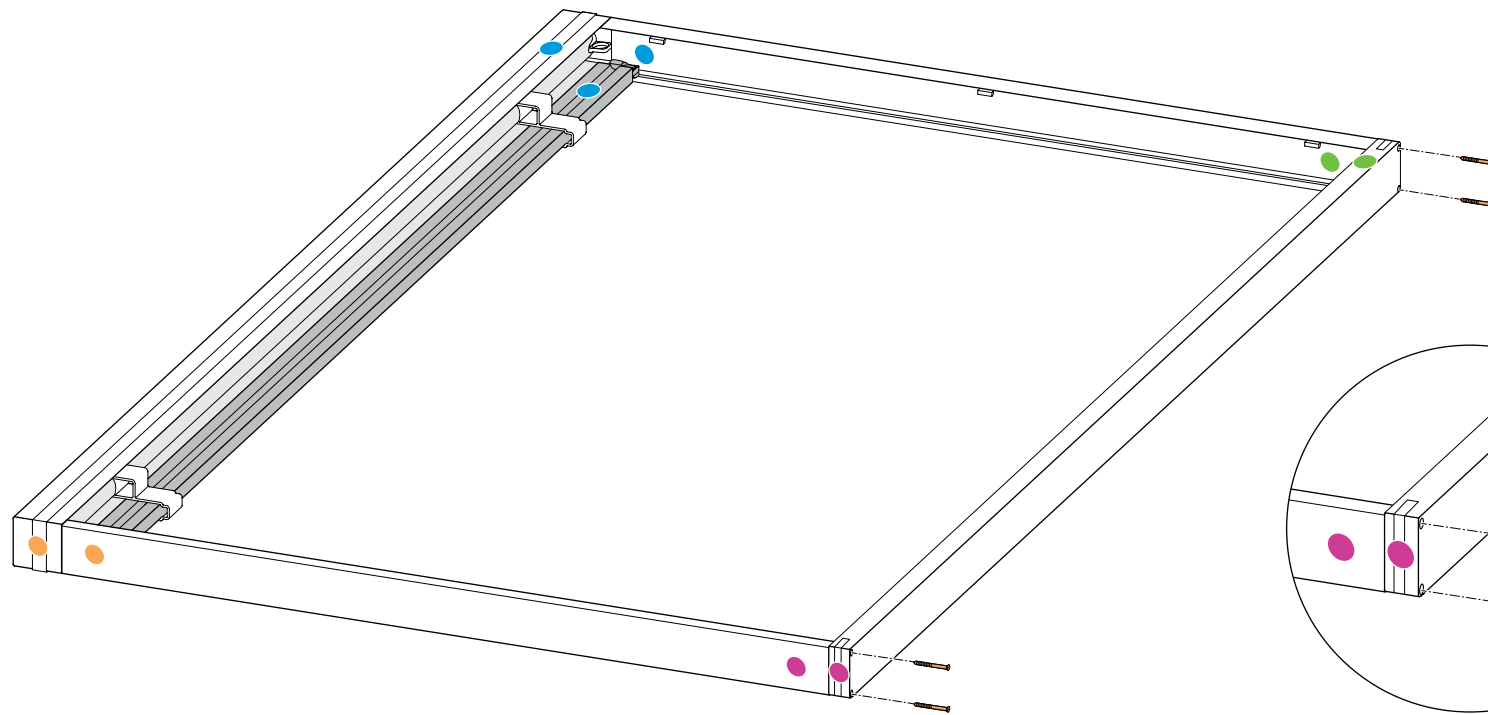

2.3

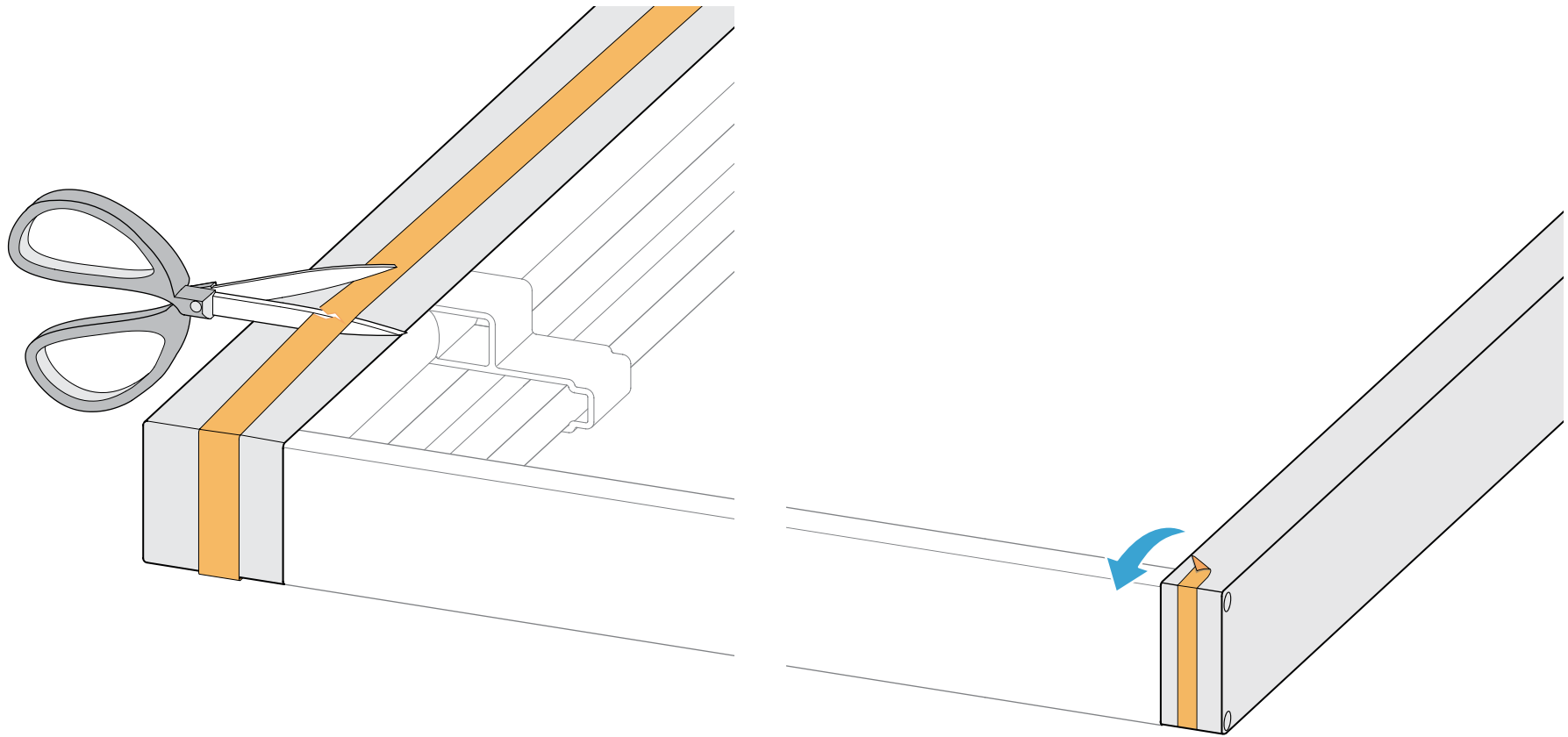

3.0 Fix frame to opening

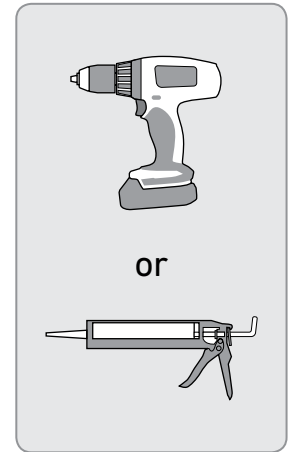
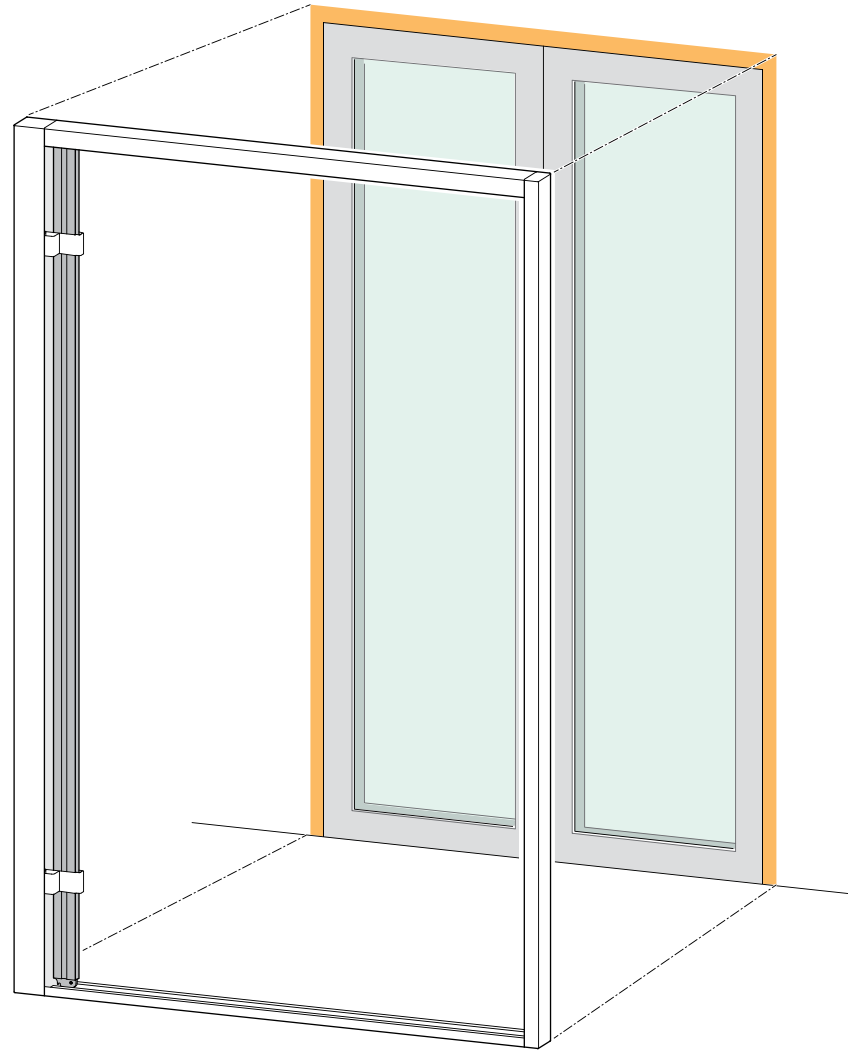
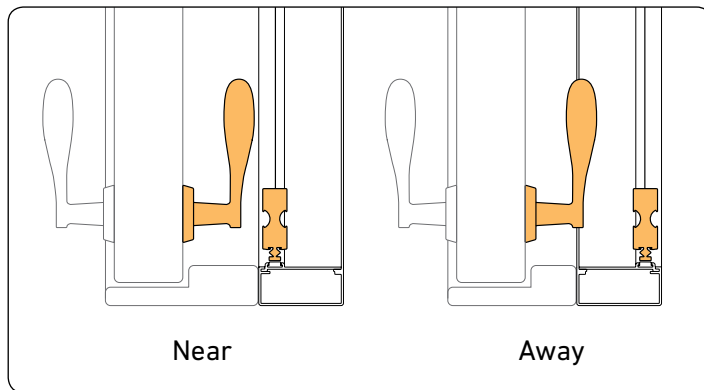
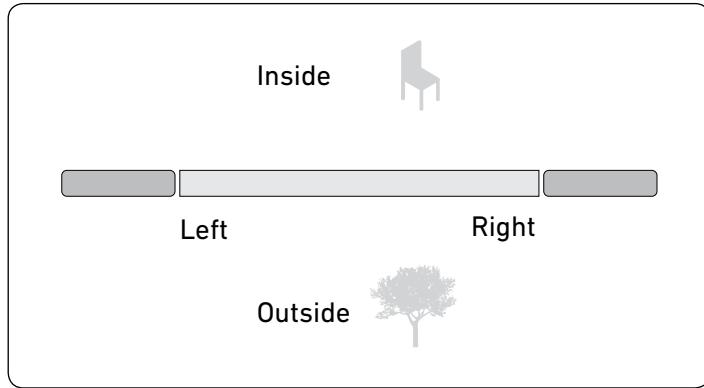

3.1

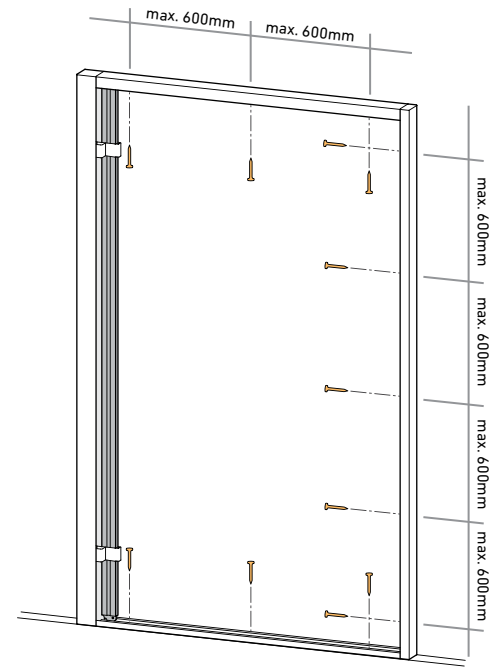
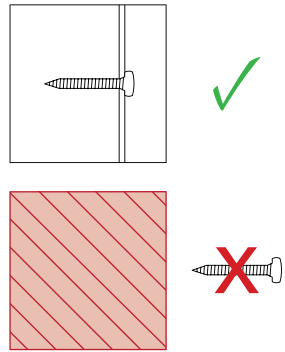
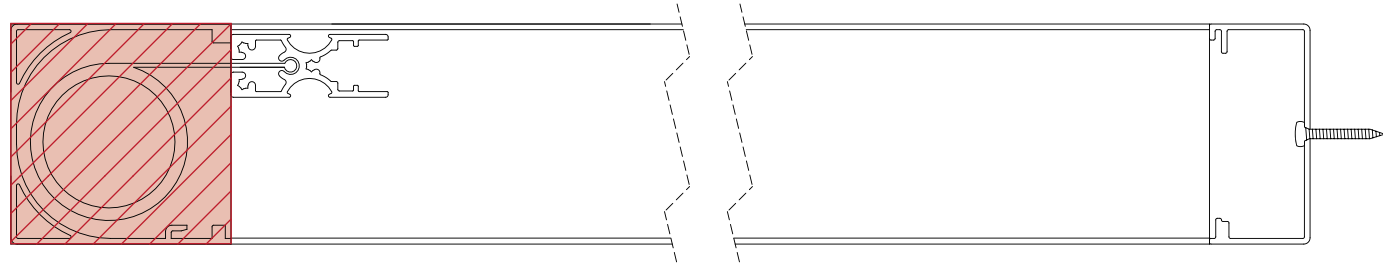
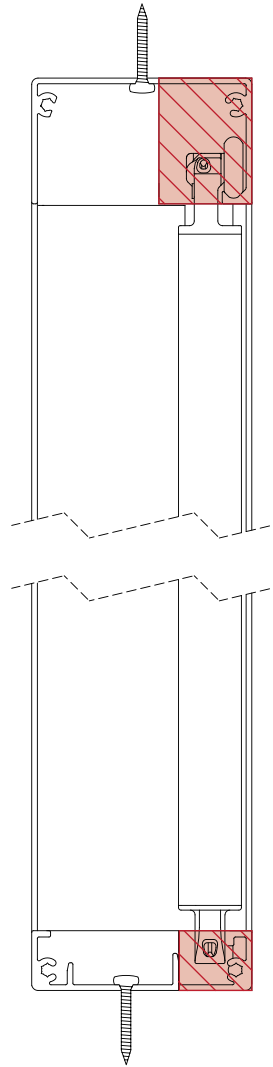

3.2

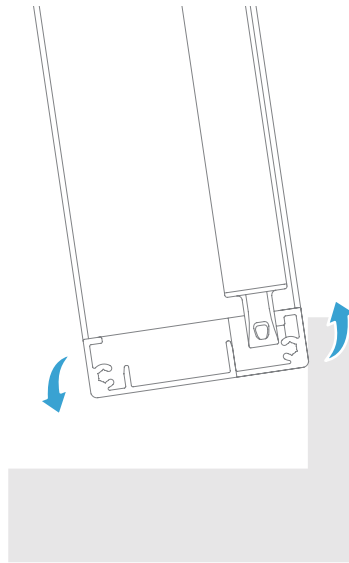
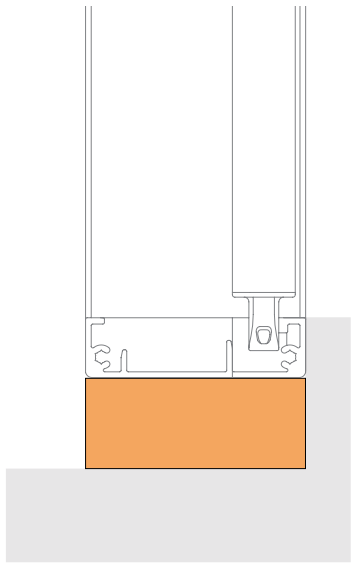

3.3

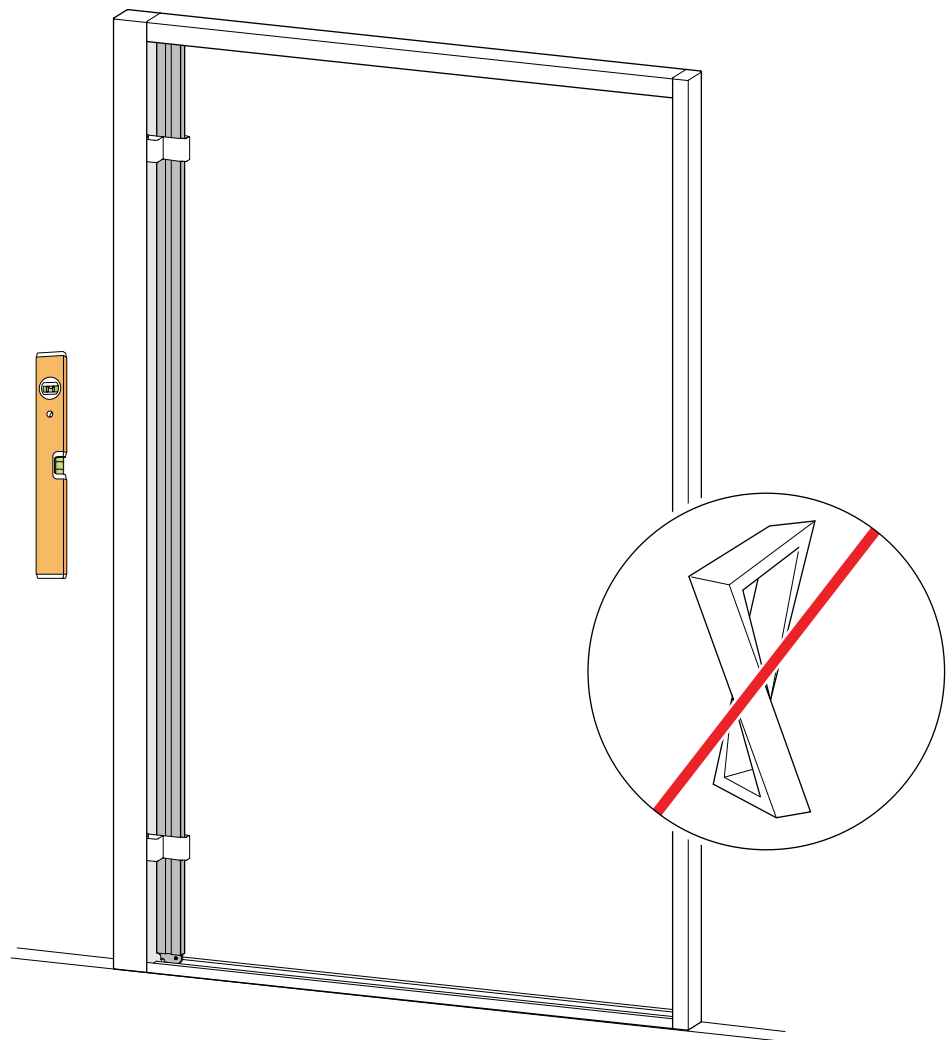

3.4

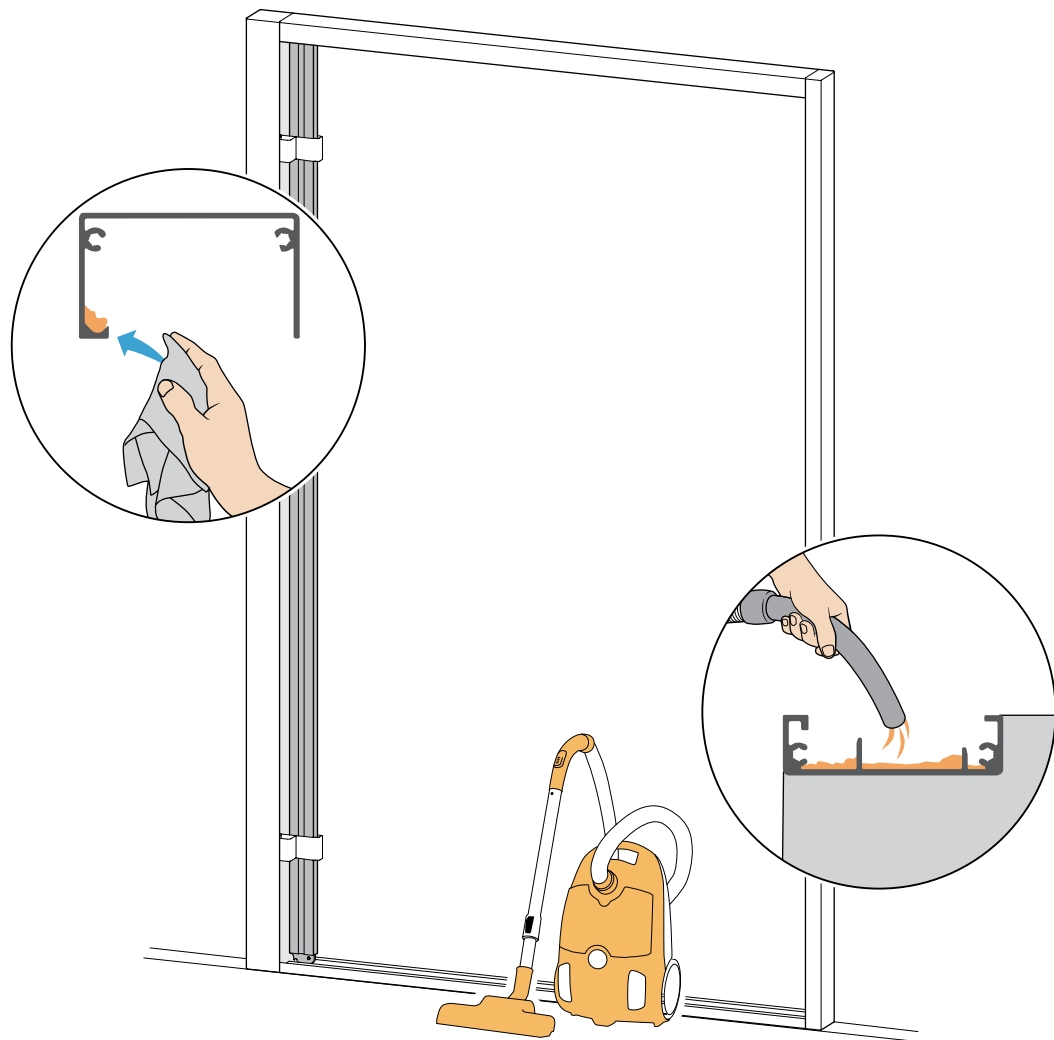

4.0 Cable screen

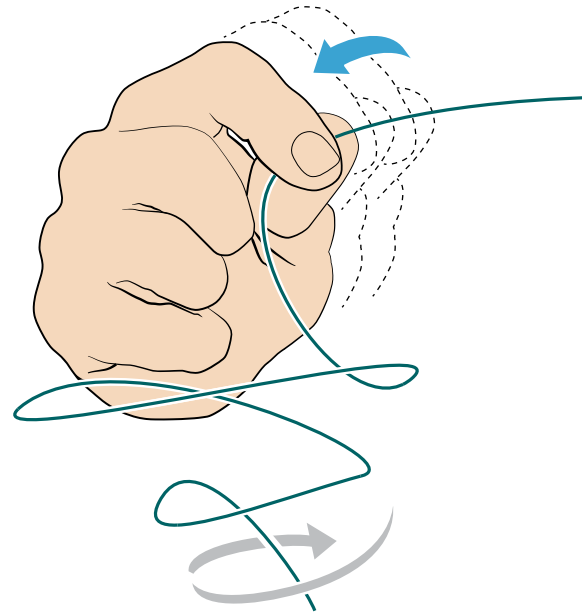
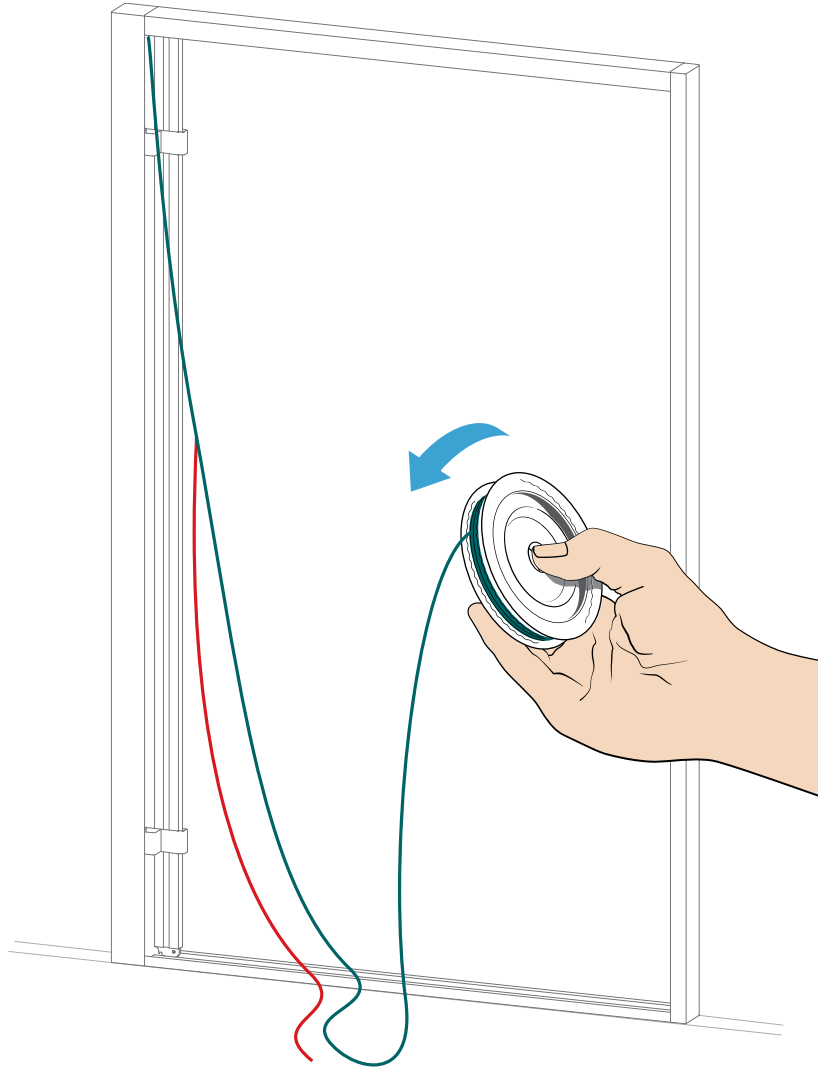

4.1

Top cable map

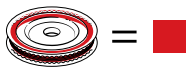
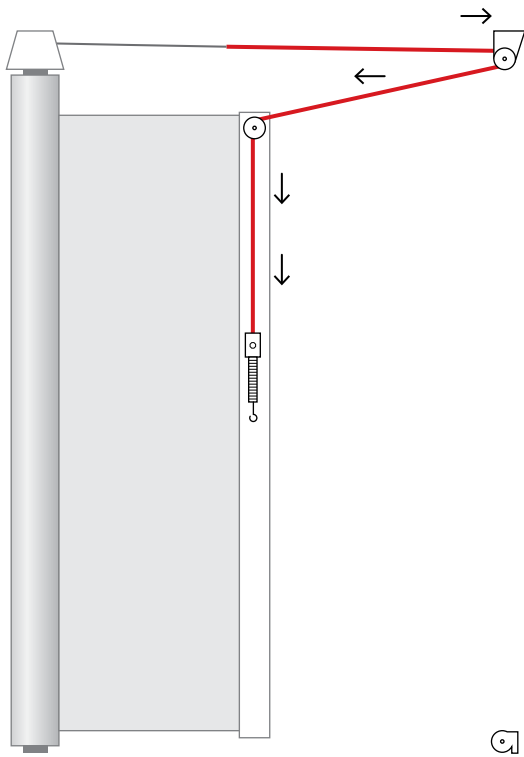

A.

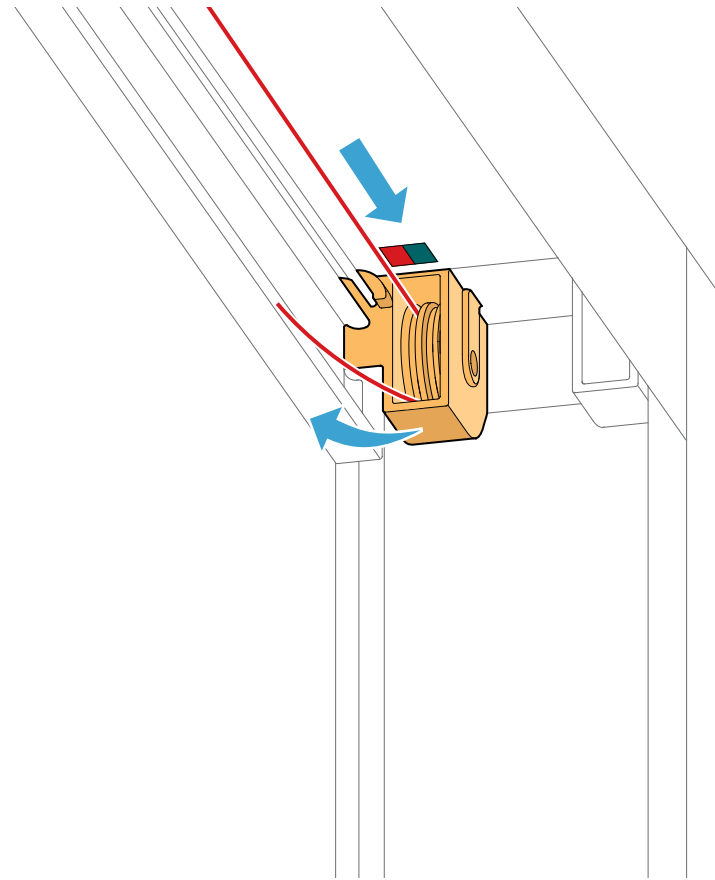

B.

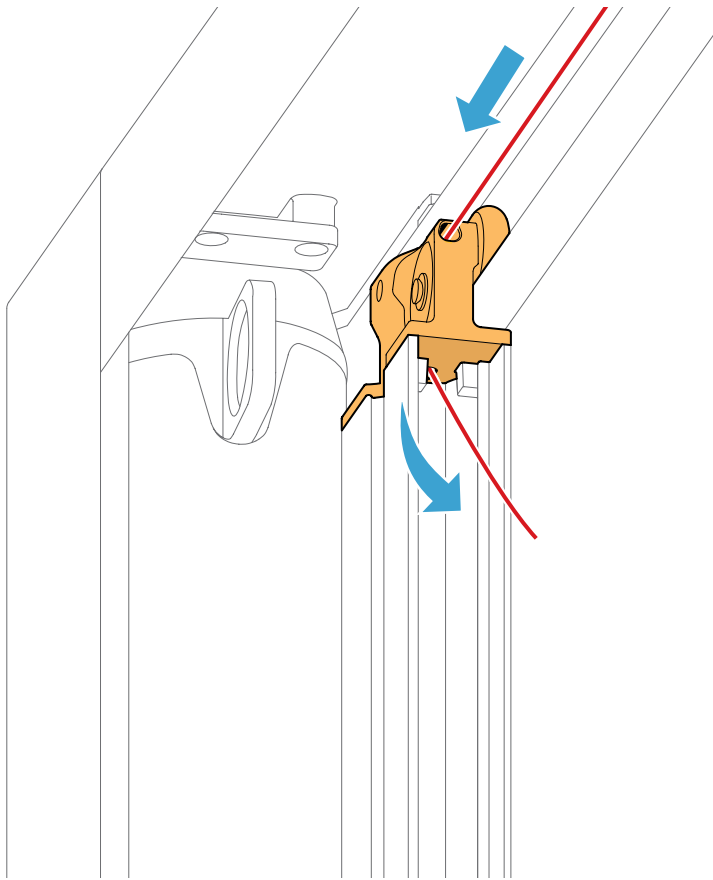

C.

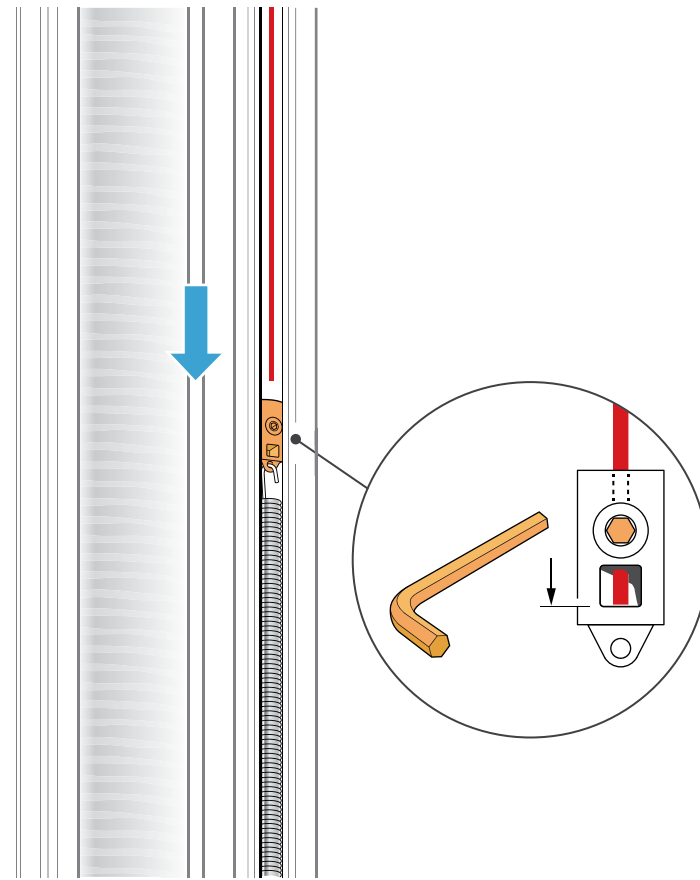

4.2

Bottom cable map

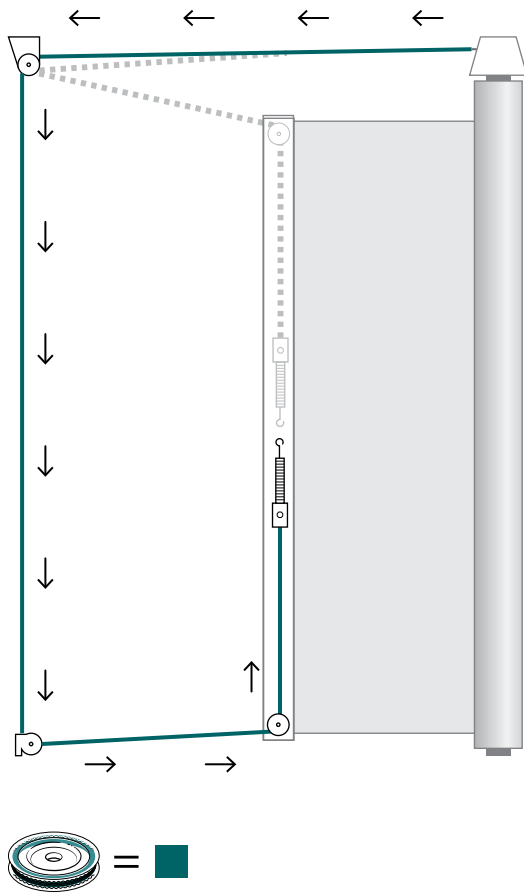

A.

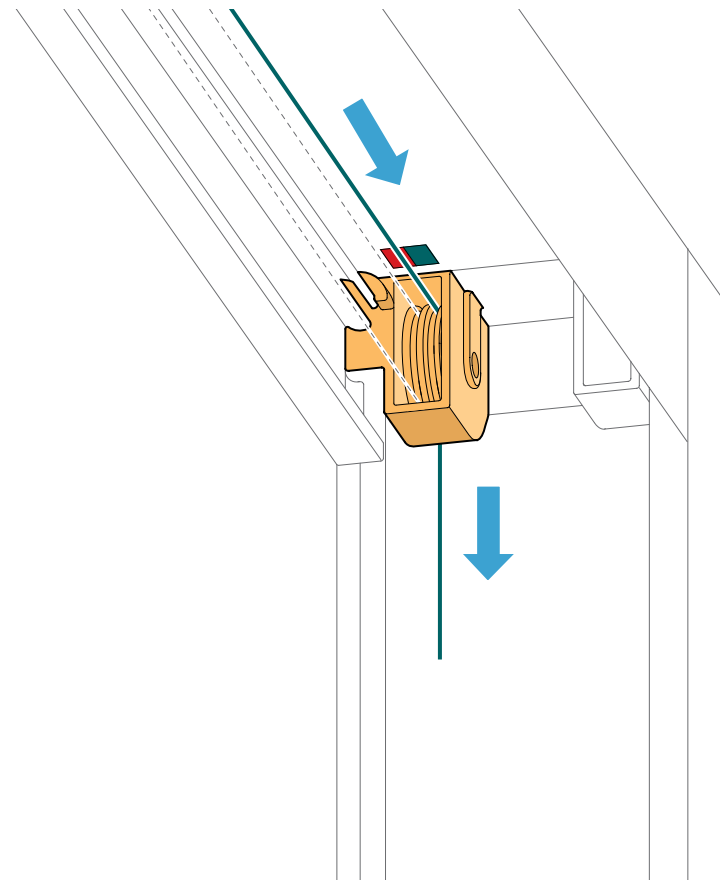

B.

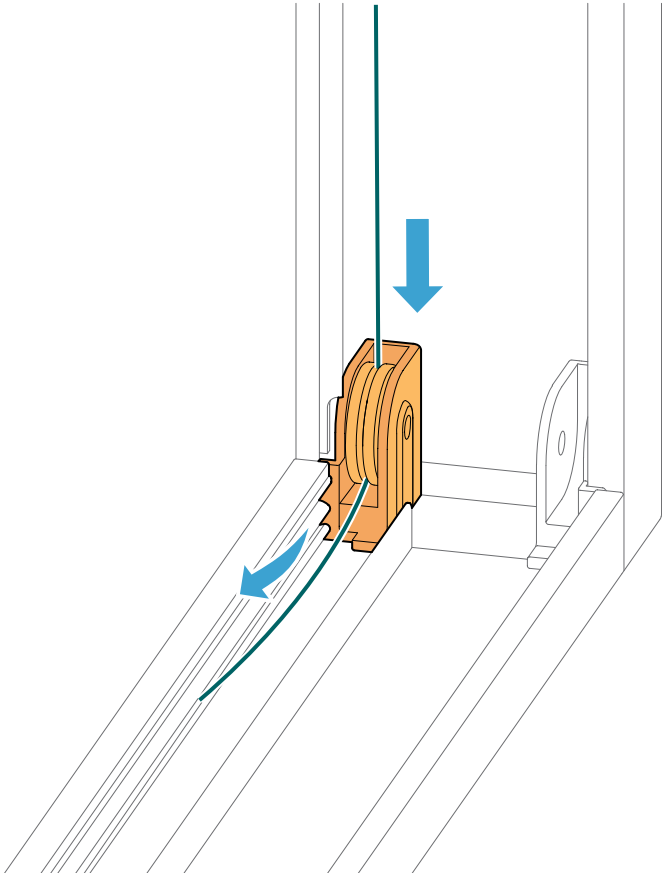

C.

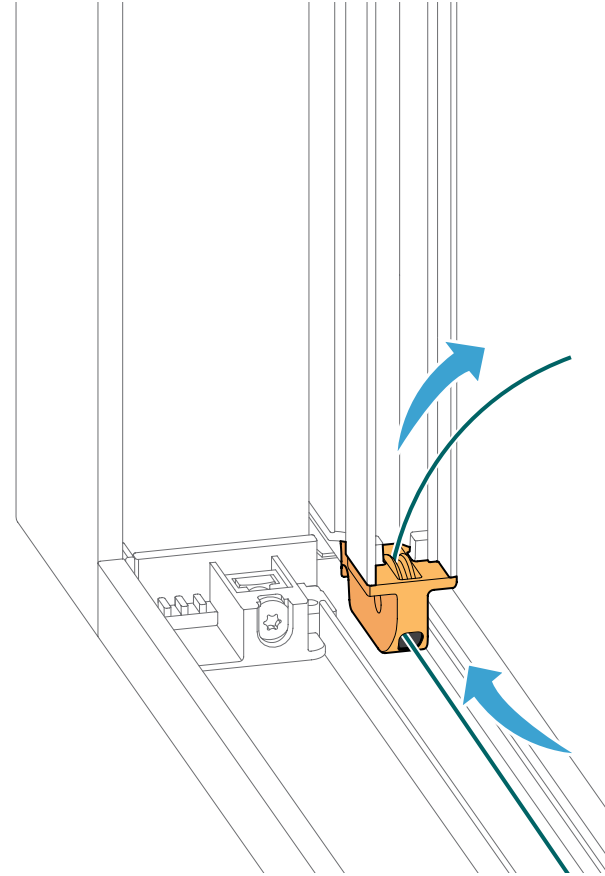

D.

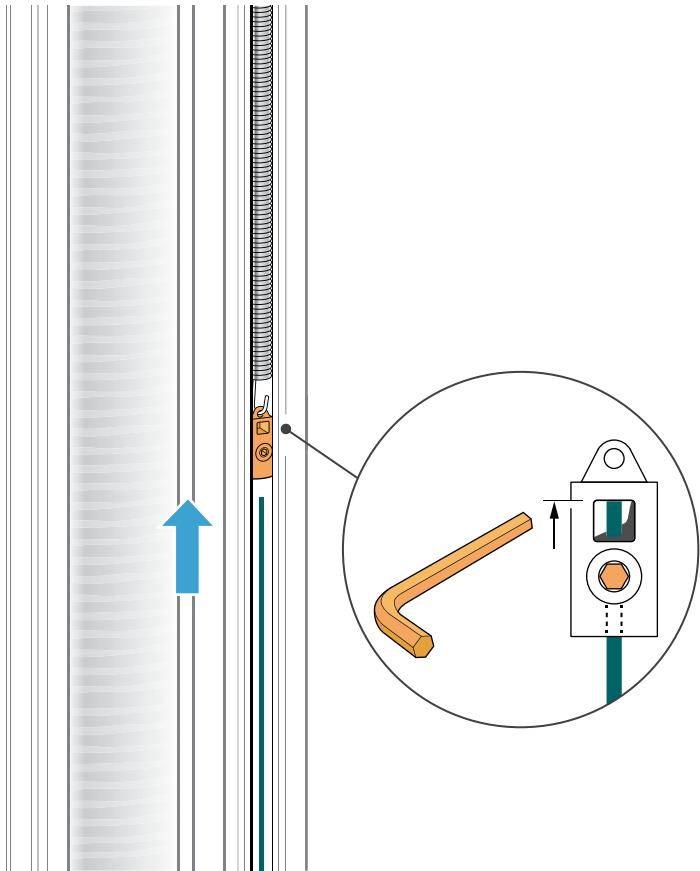

5.0 Tension

A.

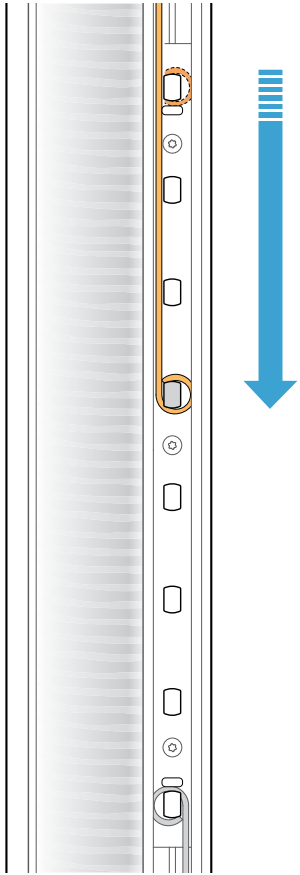

B.

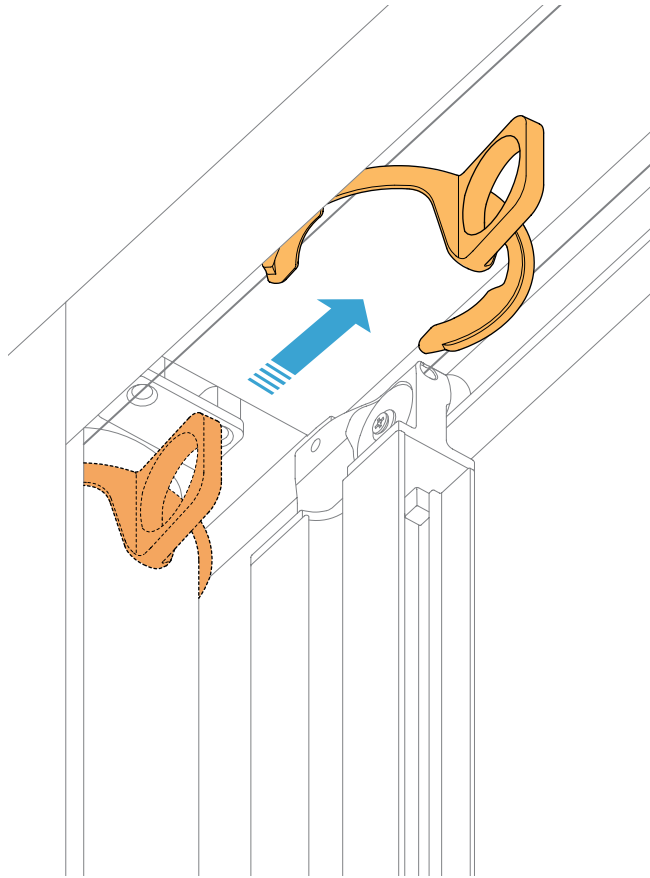

C.

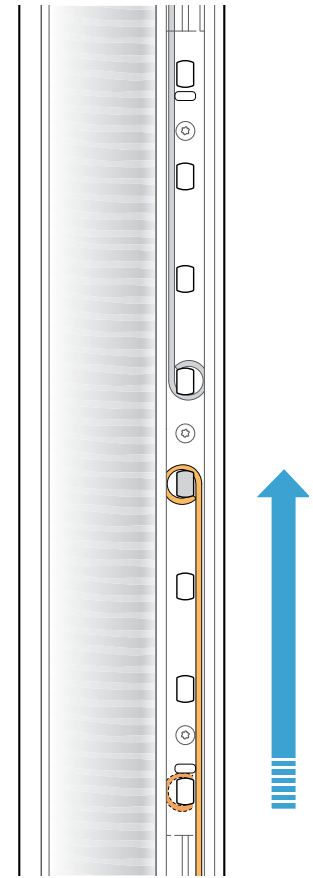

D.

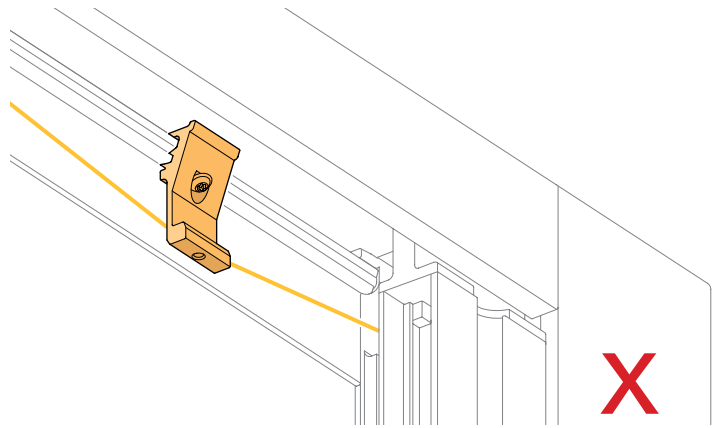
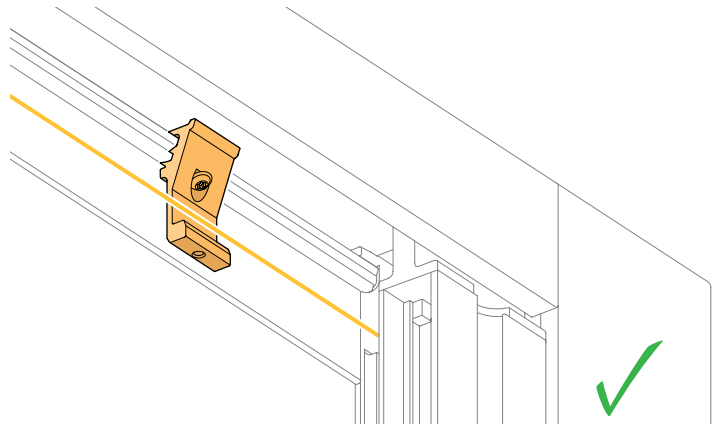

E.

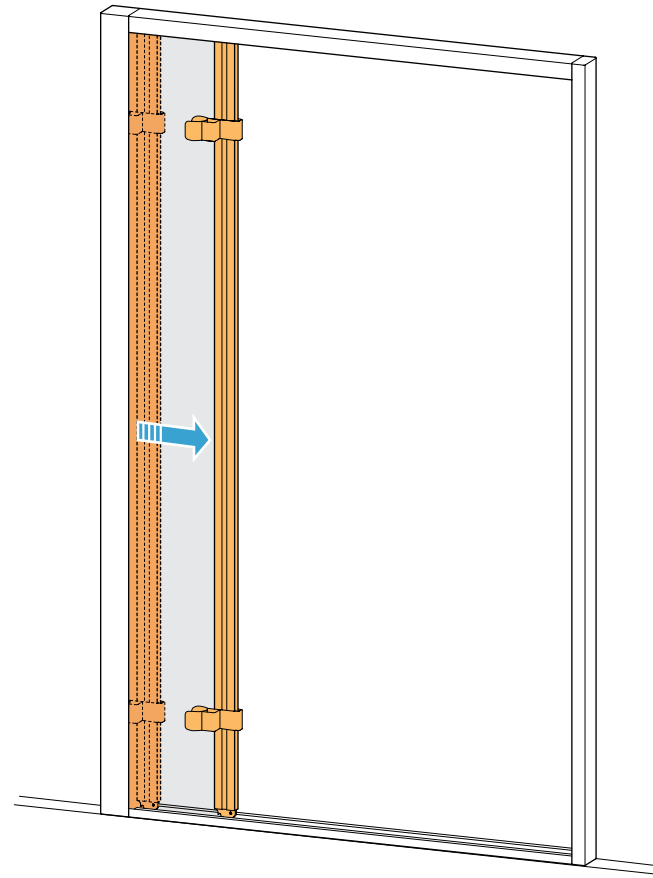

F.

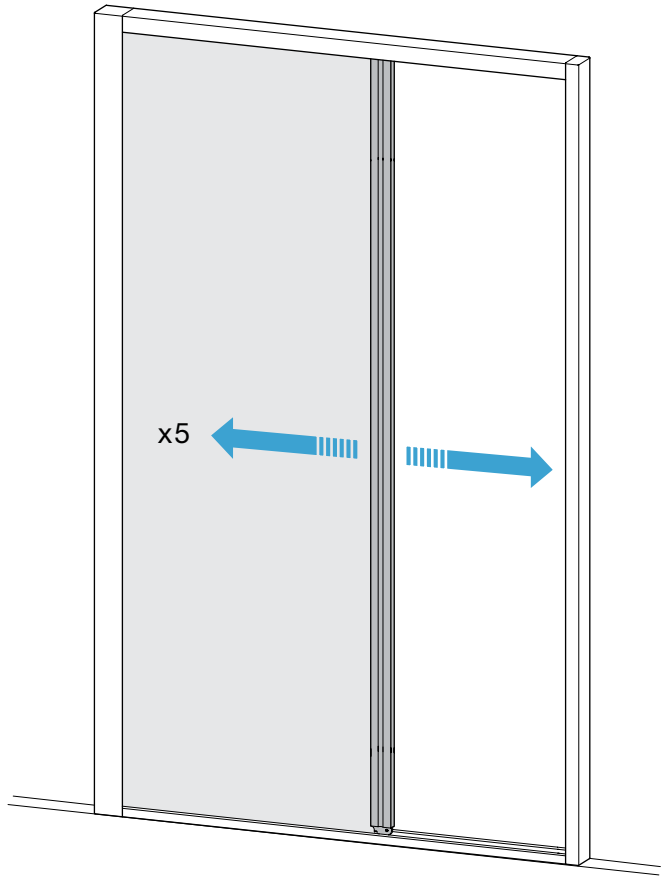

6.0 Adjust if required

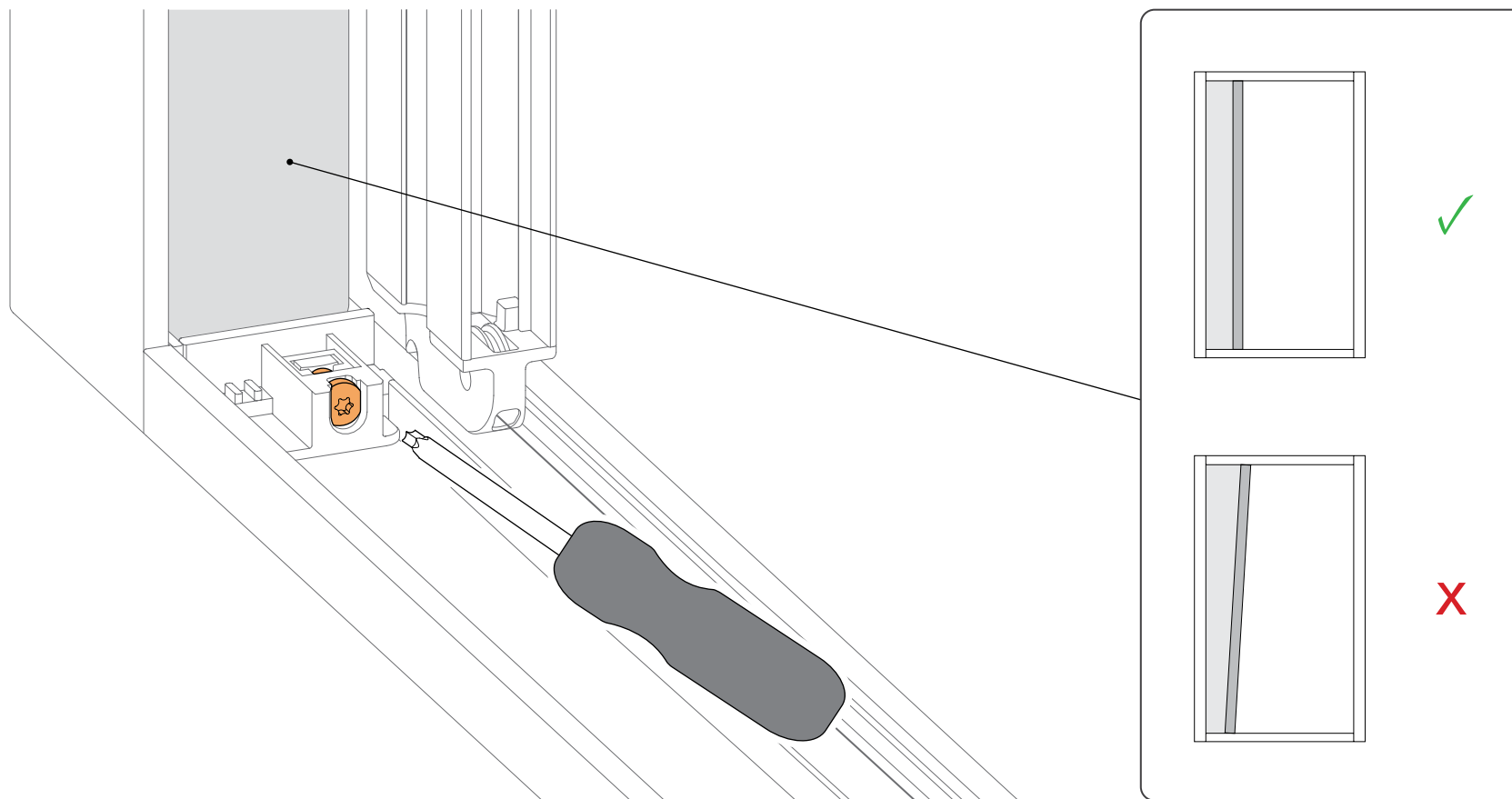

7.0 Install covers

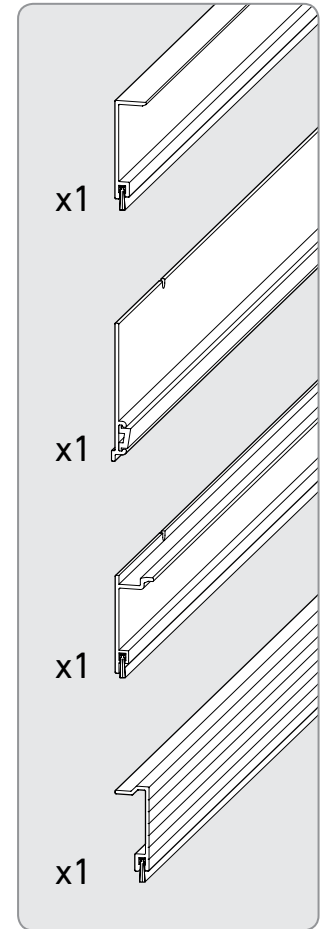
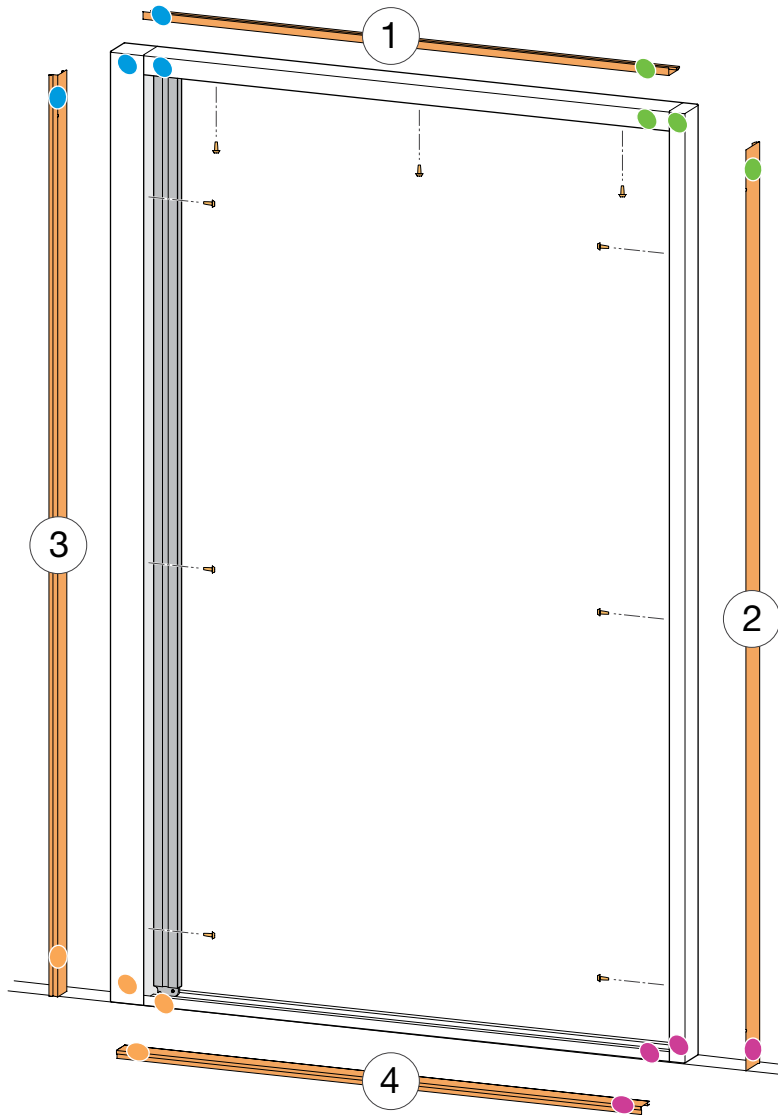

+

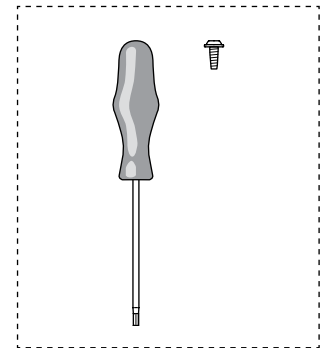

7.1

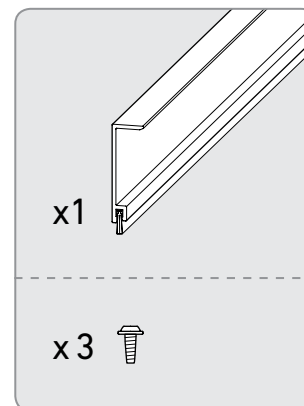
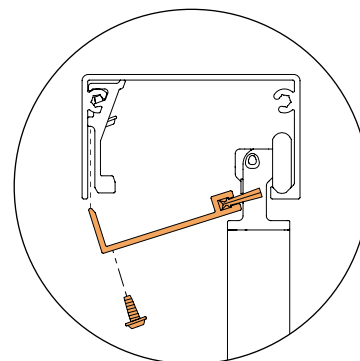
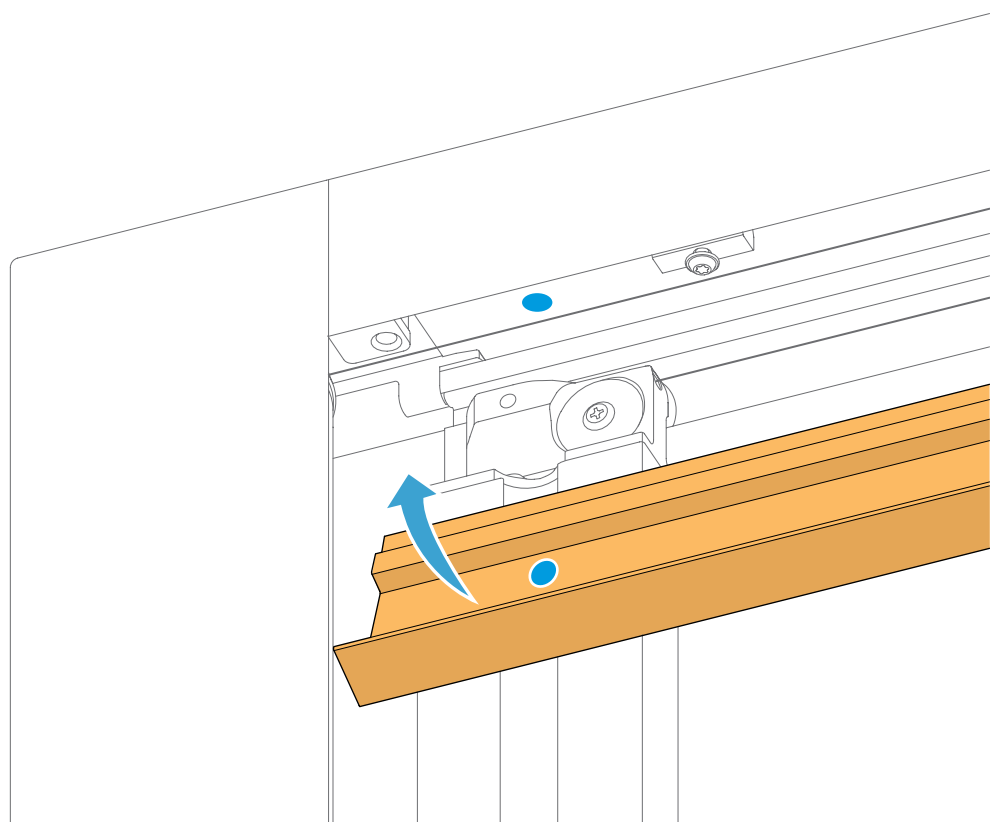

7.2

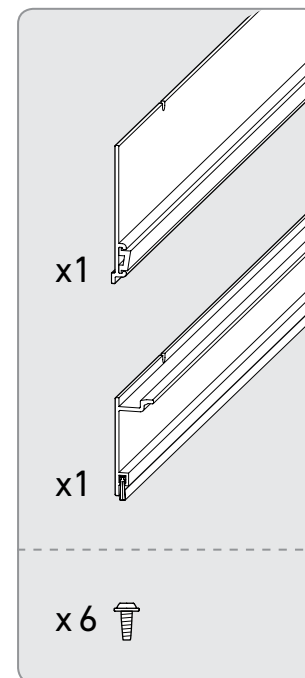
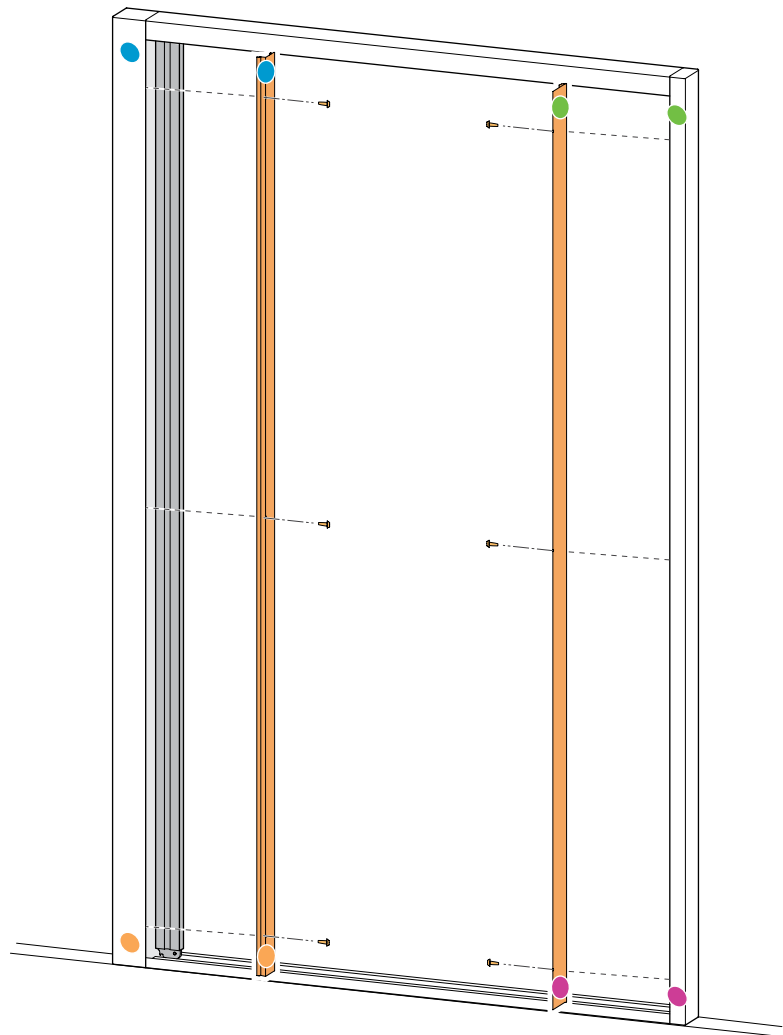

7.3

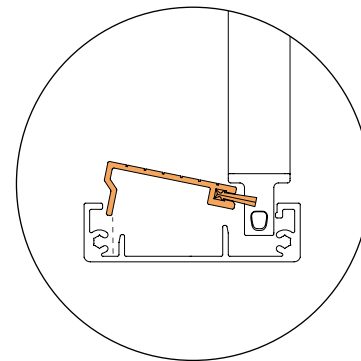
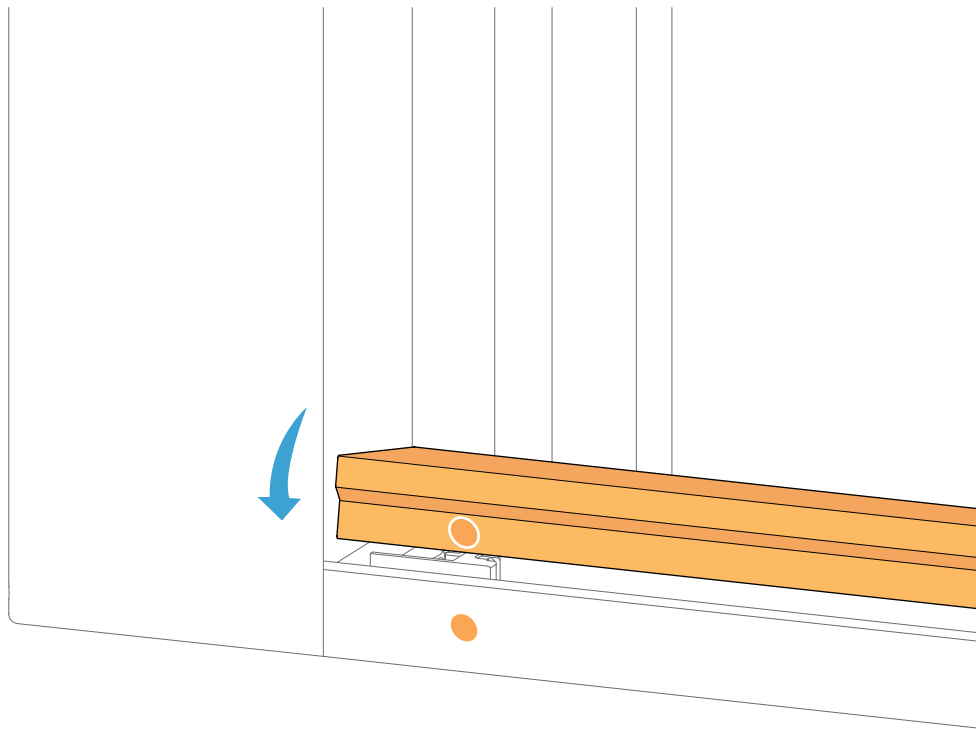
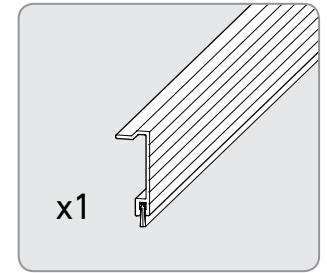

8.0 Install screen stile cover

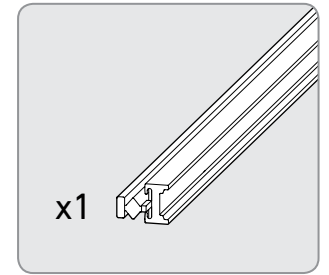
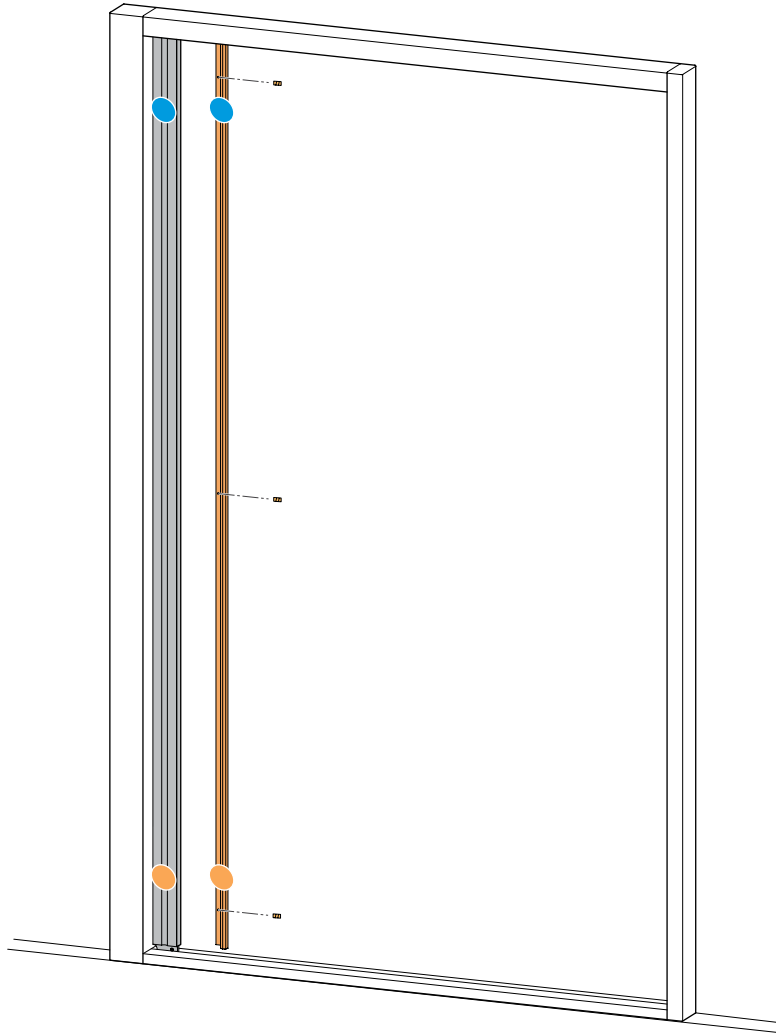

+

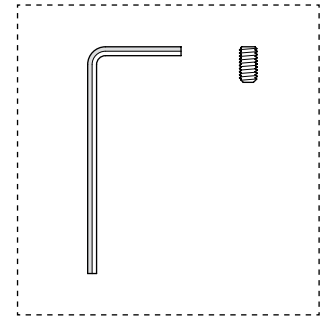

8.1

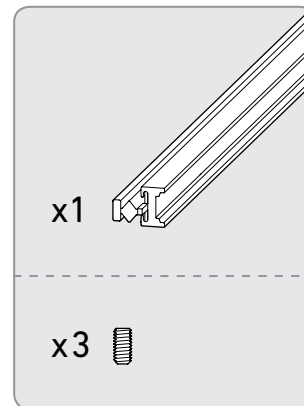
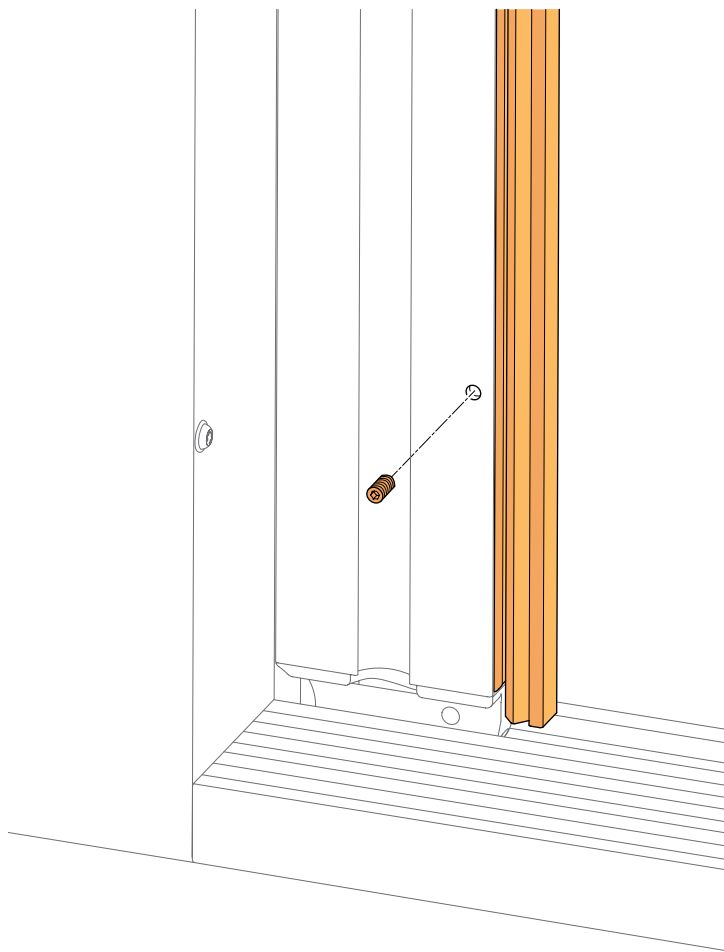

Centor Australia
+61 7 3868 5777
mail.au@centor.com

Centor Europe
+44 (0) 121 701 2500
mail.uk@centor.com

Centor North America
+1 630-957-1000
mail.us@centor.com

centorhardware.com

centor®